

# THE PLATINUM PACKAGING GROUP

## PLAT*Machinery*

### Front & Back Automatic Label Applicator System

Standard front/back systems come complete with an 8-foot by 6-inch chain link conveyor, a powered top hold down, dual applicator head I/O mounts, a microprocessor controller hung from an articulator arm, guide rails, and a spacer wheel assembly. The conveyor height is fully adjustable between 32 and 39 inches and capable of handling products up to 6-inches wide. Each conveyor system includes heavy duty construction, robust locking casters, vertical, horizontal and swivel adjustments for applicator head mounting and a heavy duty 1-horsepower adjustable speed motor.

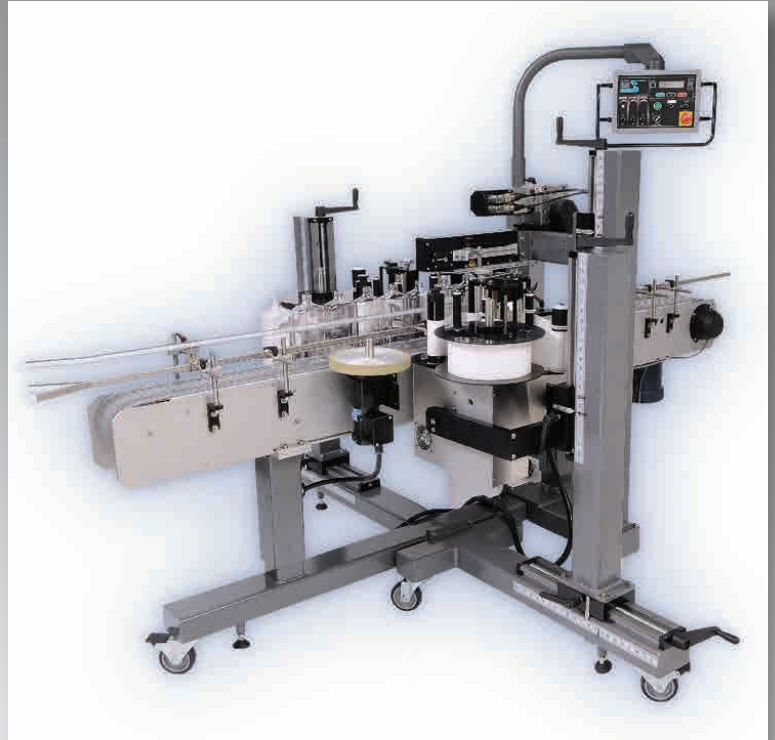

- Compatible with our ST600, ST1100, ST2100, and PA4000 automatic label applicators.
- Capable of running at speeds of up to 600, 1100, or 2100 linear inches per minute, respectively.
- Heavy duty construction specifically designed for industrial applications.
- Stainless steel and anodized aluminum provide protection from corrosive environments.
- Solid construction ensures even product handling resulting in extremely accurate label placement.
- Fully adjustable I/O mounts permit the applicator head to be oriented at any attitude for side, top or bottom label placement.
- Handles a wide assortment of product and label sizes.

# THE PLATINUM PACKAGING GROUP

## PLAT *Machinery*

### Front & Back Automatic Label Applicator System

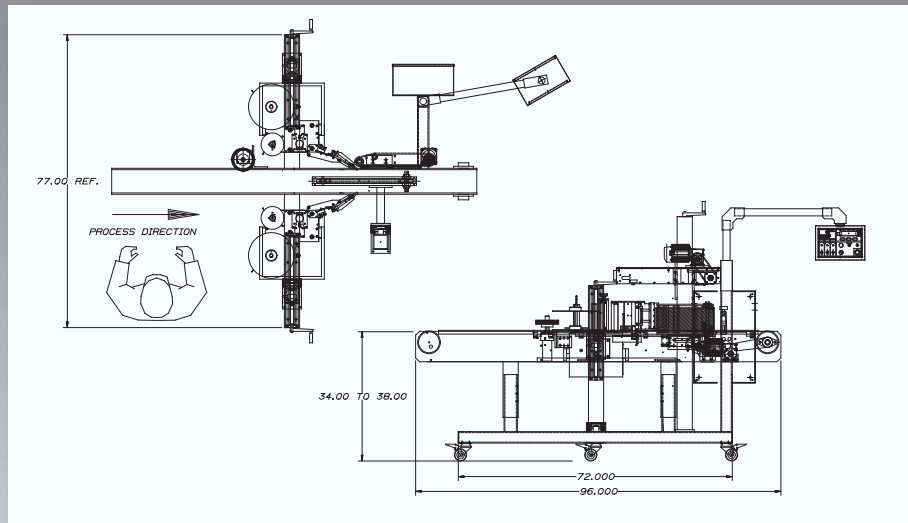

### Applicator System Specifications

<b>Speed:</b>	600/1100/2100 linear inches per minute
<b>Accuracy:</b>	± 1/32 of an inch with consistent product dimensions
<b>Control Electronics:</b>	Microprocessor Controller
<b>Label Size:</b>	Minimum: 1/2-inch by 1/2-inch Maximum: 6-1/2" by 18.00"
<b>Electrical:</b>	110 VAC, 50/60 Hertz, 15 Amps
<b>Product Detection:</b>	Photoelectric
<b>Label Capacity:</b>	6-1/2" Web Width, 12-inch/16-inch/18-inch diameter label roll capacity with a 3-inch core
<b>Options:</b>	Stainless Steel Base Stainless Steel Wash Down Optional Wrap Station 3/4/5 Panel Station Optional Conveyor Lengths and Widths Dual Powered Alignment Belts Error/Warning Light Pole Secondary Impression Kits Custom Product Handling Gap Transporter Belts

THE PLATINUM PACKAGING GROUP

tel: (562) 630-6700

7627 Somerset Blvd., Paramount, CA 90723

sales@platinumpkggroup.com