

THE PLATINUM PACKAGING GROUP

PLAT*Machinery*

TS1100 Automatic Label Applicator Head

The ST1100 Automatic Label Applicator is a high performance labeling head capable of speeds of up to 1100 linear inches per minute. It comes complete with a direct drive DC stepper motor, powered rewind, a 6.5-inch web width, and a standard 12-inch diameter label roll capacity. Under microprocessor control, the ST1100 is accurate to $\pm 1/32$ of an inch.



- Heavy duty construction specifically designed for industrial applications.
- Microprocessor controller gives flexible and accurate label placement.
- Stainless steel and anodized aluminum provide protection from corrosive environments.
- Solid drive construction ensures even pressure to the label web resulting in extremely accurate label placement.
- The applicator head can be oriented to any attitude for side top or bottom placement.
- Handles a full assortment of label shapes and sizes.

THE PLATINUM PACKAGING GROUP

PLAT *Machinery*

TS1100 Automatic Label Applicator Head

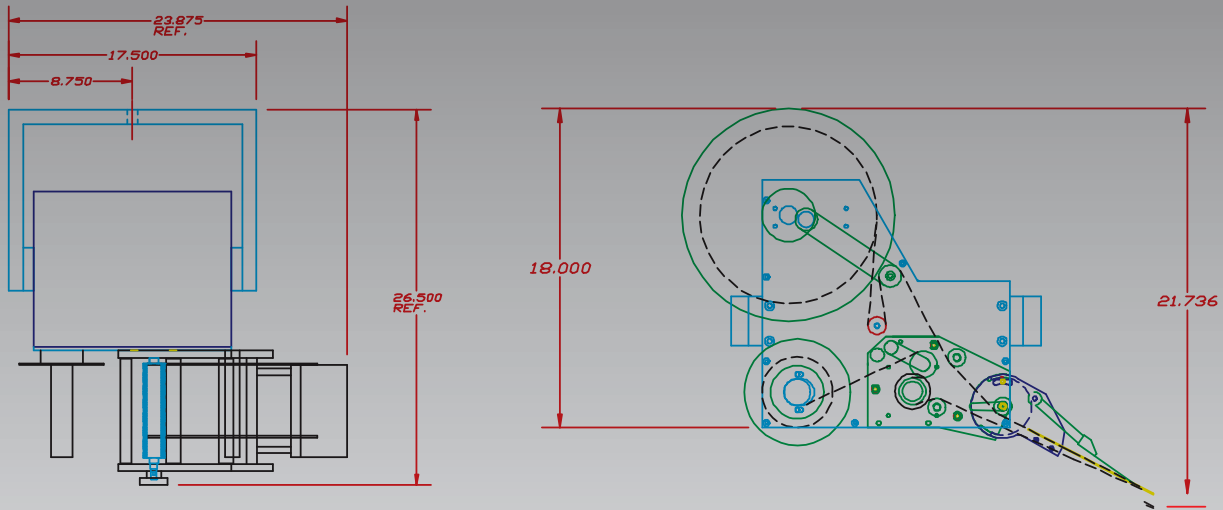

TS1100 Label Applicator Specifications

Speed	<i>1100 linear inches per minute.</i>
Accuracy	<i>± 1/32 of an inch with consistent product dimensions</i>
Control Electronics	<i>Microprocessor Controller</i>
Label Size	<i>Minimum: Wipe-on: 1/2" by 1/2"; Wrap: 1" by 1" Maximum: Wipe-on: 6-1/2" by 18.00"; Wrap 6-1/2" by 10.00"</i>
Electrical	<i>115 VAC, 50/60 Hertz, 5 Amps</i>
Product Detection	<i>Photoelectric</i>
Label Capacity	<i>6.5" web width, 12" diameter label roll, 3" core</i>
Options	<i>Low Label Warning Out of Label Warning Web Break Warning Rate Compensation Label/Product Counter Clear Label Sensor Hot Stamp Imprinter Oversize Web Width Imprint Verification</i>

THE PLATINUM PACKAGING GROUP

tel: (562) 630-6700

7627 Somerset Blvd., Paramount, CA 90723

sales@platinumpkggroup.com